

Airport Lighting Specialists Pty Ltd



TESTED

ZA290LIR

INSET NVG COMPATIBLE HELIPAD LIGHT

Features

ZA290 LED lights are NATA certified and ICAO / MOS139 compliant.

Tested to meet the requirements of NSW DOH and ACT Helicopter Ambulance

Designed for harsh conditions.

LED light source – extremely long life.

Power consumption 10% of incandescent lamps.

Power savings of 50-75% over entire system.

NVG compatible, Infra-red output at 850nm.

Glass Lenses, anodised aluminium body.

Power options: low voltage 24 or 48 V DC or 230VAC mains power (dimnable with suitable driver)

Colours

ZA290LIR lights are available in all CASA and ICAO aviation colors.

Green –	TLOF, FATO
White –	TLOF, FATO, Flight path alignment.
Blue –	Taxiway, Parking position.
Yellow –	Holding Point. Flight Path Alignment
Red -	Obstacle marking

Infra-Red - Dominant wavelength:
850 Nanometers.

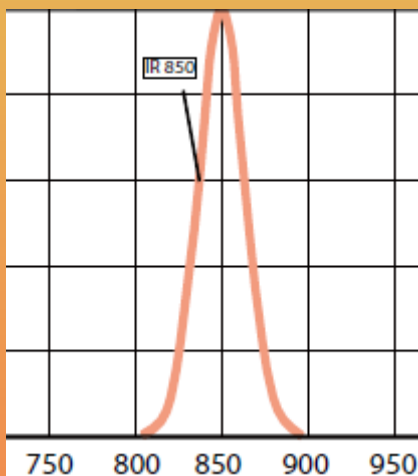

Mounting (typical)

ZA290LIR lights are fitted into a seating pot which is installed into the pavement using epoxy grout adhesive.

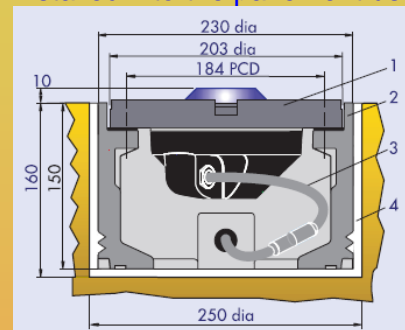

1. ZA292 IEC fitting
2. ZM203(I) seating pot
3. Secondary lead
4. Grout



Viewed with IR camera

Airport Lighting Specialists Pty Ltd

Phone + 61 (0)3 9432 0511
sales@airportlighting.com.au www.airportlighting.com.au
Factory 5 / 20 Peel Street, Eltham, Victoria, 3095



TESTED